

# 90-Ton Link-Belt HTC-8690

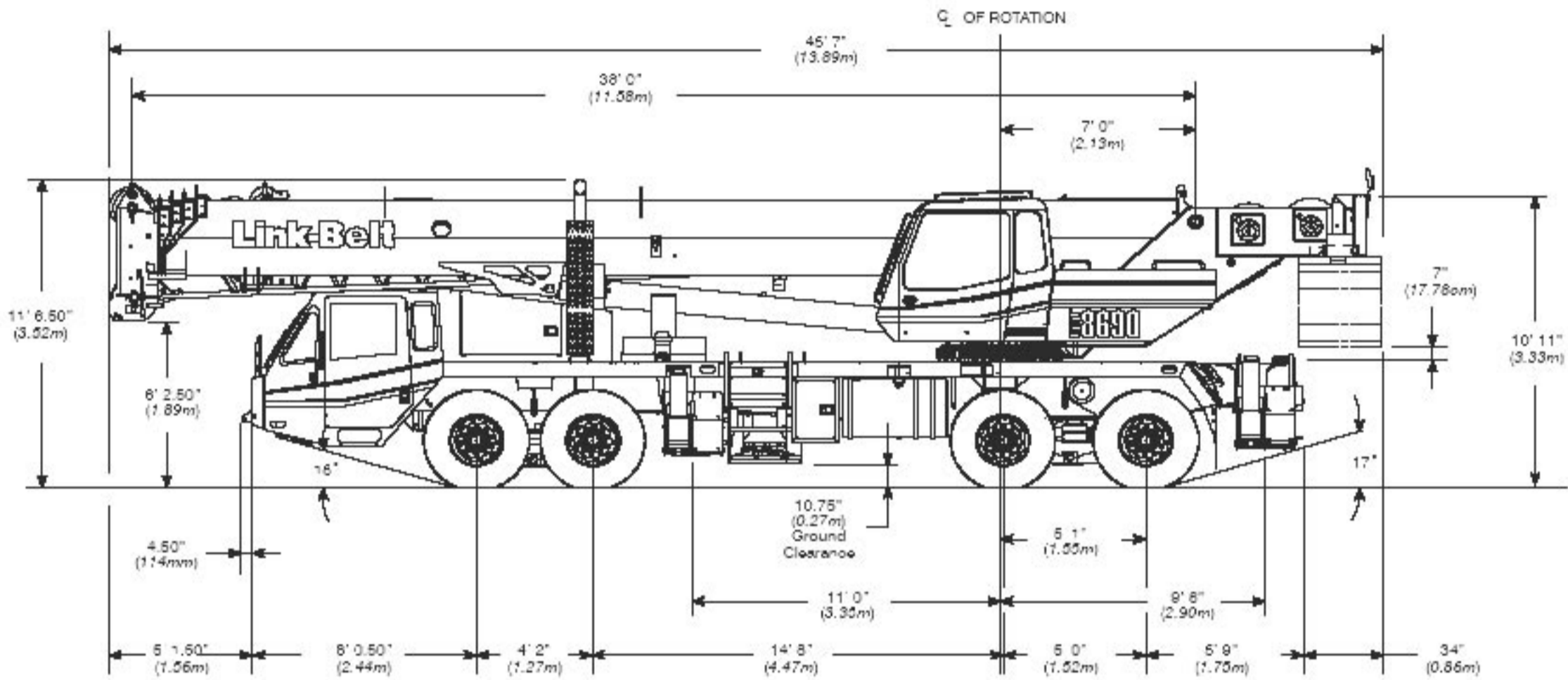

Turning Radius – Front Wheel (8x4) Steering	English	Metric
Wall to wall over carrier	48' 4"	14.7m
Wall to wall over boom	49' 2"	15.0m
Wall to wall over boom attachment	51' 0"	15.5m
Curb to curb	44' 1"	13.4m
Centerline of tire	43' 4"	13.2m

Turning Radius – All Wheel (8x8) Steering	English	Metric
Wall to wall over carrier	32' 9"	10.0m
Wall to wall over boom	34' 1"	10.4m
Wall to wall over boom attachment	35' 8"	10.9m
Curb to curb	28' 4"	8.6m
Centerline of tire	27' 7"	8.4m

Tail Swing	English	Metric
With counterweight	13' 8"	4.2m
Without counterweight	13' 1"	4.0m

Overall Width	English	Metric
With up to 32,500 lb (14 741.8kg) counterweight	8' 6"	2.6m
With 39,500 lb (17 916.9kg) counterweight	11' 0"	3.4m

Not To Scale

